



ⓘ Discontinued

Commercial status

Discontinued on: 31 October 2017

End-of-service on: 31 October 2017

XMLP016BC21VQ has not been replaced. Please contact your customer care center for more information.

Main

Range of product	OsiSense XM
Product or component type	Electronic pressure sensors
Pressure sensor type	Pressure transmitter
Pressure sensor name	XMLP
Electrical circuit type	Control circuit
Pressure rating	16 bar
Local display	Without
Controlled fluid	Air (-20...120 °C) Fresh water (0...120 °C) Hydraulic oil (-20...120 °C) Gas (-20...120 °C) Refrigeration fluid (-20...120 °C)
Fluid connection type	G 1/4A (male) conforming to DIN 3852-E
Electrical connection	1 male connector EN 175301-803-A (ex DIN43650) 3 pins
[Us] rated supply voltage	12...24 V DC SELV (voltage limits: 8...30 V)
Current consumption	< 20 mA
Type of output signal	Analogue
Analogue output function	4...20 mA, 2-wire
Quantity per set	Set of 40
Type of packing	Group

Complementary

Pressure setting range	0...16 bar
Maximum permissible accidental pressure	32 bar
Destruction pressure	160 bar
Materials in contact with fluid	Stainless steel type 17-4PH Stainless steel type AISI 304 Fluorocarbon FKM (Viton)
Operating position	Any position
Protection type	Load short-circuit Reverse polarity
Electromagnetic compatibility	Susceptibility to electromagnetic fields conforming to EN/IEC 61000-4-3 10 V/m 80...1000 MHz Electrical fast transient/burst immunity test conforming to EN/IEC 61000-4-4 2 kV

1.2/50 μ s shock waves immunity test conforming to EN/IEC 61000-4-5 500 V 12 Ohm, 1 kV 42 Ohm
 Radiated RF fields conforming to EN/IEC 61000-4-6 10 V 0.15...80 MHz
 Electrostatic discharge immunity test conforming to EN/IEC 61000-4-2 8 kV air, 4 kV contact

[Uimp] rated impulse withstand voltage	0.5 kV
Response time on output	< 5 ms 92 % of full scale
Measurement accuracy	+/- 0.5 % of the measuring range
Resolution	Infinity
Drift of the sensitivity	+/- 0.02 % of measuring range/°K
Drift of the zero point	+/- 0.02 % of measuring range/°K
Long term stability	+/- 0.2 % of the measuring range
Mechanical durability	10000000 cycles
Net weight	0.05 kg
Diameter	30 mm
Length	25 mm

Environment

Standards	EN/IEC 61326-1 CE
Product certifications	RCM EAC CULus
Protective treatment	TC
Ambient air temperature for operation	-30...100 °C
Ambient air temperature for storage	-30...100 °C
Vibration resistance	20 gn (f = 10...2000 Hz) conforming to EN/IEC 60068-2-64
Shock resistance	25 gn for 11 ms conforming to EN/IEC 60068-2-27
IP degree of protection	IP65 conforming to EN/IEC 60529

Packing Units

Package 1 Weight	0.060 kg
Package 1 Height	0.770 dm
Package 1 width	1.740 dm
Package 1 Length	2.770 dm

Contractual warranty

Warranty	18 months
----------	-----------

Dimensions

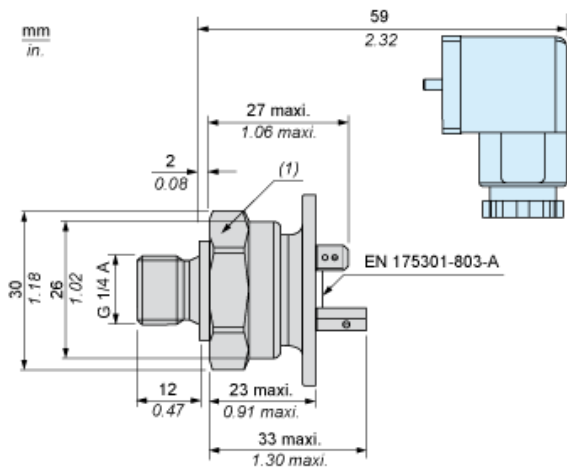

(1) SW27 Tightening torque ≤ 25 Nm / 221 Lb-in

Wiring Diagram

2-Wire Technique (4-20 mA)

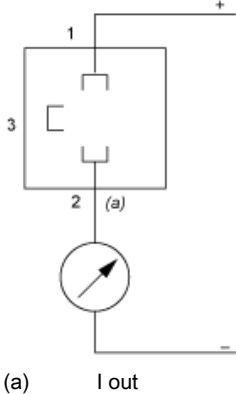

(a) I out

Curves

