



Main

Range of product	Modicon STB distributed I/O solution
Product or component type	Basic digital output kit
Kit composition	STBDDO3705 module STBXBA3000 base STBXTS1180, 18-terminal screw type connector
Discrete output number	16
Discrete output type	Solid state
Discrete output voltage	24 V
Discrete output voltage type	DC

Complementary

Discrete output current	500 mA
Discrete output logic	Positive
Output voltage	19.2...30 V DC
Absolute maximum voltage	35 V 1.3 ms
Response time	2 ms off-to-on 2 ms on-to-off
Cold swapping	Yes
Hot swapping	No for basic NIMs
Protection type	Power protection integrated fuse on PDM time lag 5 A Reverse polarity protection Short-circuit protection Thermal overload protection
Insulation between channels and logic bus	1500 V for 1 minute
Maximum leakage current	0.4 mA at state 0 30 V
Maximum load capacitance	10 µF
Maximum load inductance	1000 mH at 4 Hz
Reset	Manual reset COM fault
Product compatibility	Power distribution module STBPDT3100/3105

I/O base STBXBA3000

[Us] rated supply voltage	24 V DC
Supply	Power distribution module
Current consumption	135 mA at 5 V DC for logic bus
Marking	CE
Overvoltage category	II
Status LED	1 LED (green)module status (RDY) 1 LED per channel (green)channel status (OUT1 to OUT16)
Height	13.9 mm
Depth	70 mm
Width	128.3 mm
Net weight	0.086 kg

Environment

Standards	EN/IEC 61131-2
Product certifications	UL CSA FM Class 1 Division 2
Pollution degree	2 conforming to IEC 60664-1
Operating altitude	<= 2000 m
IP degree of protection	IP20 conforming to EN 61131-2 class 1
Ambient air temperature for operation	0...60 °C (without derating)
Ambient air temperature for operation	32...140 °F without derating
Ambient air temperature for storage	-40...85 °C without derating
Ambient air temperature for storage	-40...185 °F without derating
Relative humidity	95 % at 60 °C without condensation
Vibration resistance	3 gn at 58...150 Hz on 35 x 7.5 mm symmetrical DIN rail 5 gn at 58...150 Hz on 35 x 15 mm symmetrical DIN rail +/-0.35 mm at 10...58 Hz
Shock resistance	30 gn for 11 ms conforming to IEC 88 reference 2-27

Packing Units

Unit Type of Package 1	PCE
Number of Units in Package 1	1
Package 1 Weight	206 g
Package 1 Height	3.5 cm
Package 1 width	8 cm
Package 1 Length	13 cm
Unit Type of Package 2	S02
Number of Units in Package 2	20
Package 2 Weight	4.546 kg
Package 2 Height	15 cm
Package 2 width	30 cm
Package 2 Length	40 cm

Offer Sustainability

Sustainable offer status	Green Premium product
REACH Regulation	REACH Declaration
EU RoHS Directive	Pro-active compliance (Product out of EU RoHS legal scope) EU RoHS Declaration
Mercury free	Yes
RoHS exemption information	Yes
China RoHS Regulation	China RoHS declaration
Environmental Disclosure	Product Environmental Profile

Circularity Profile	End of Life Information
WEEE	The product must be disposed on European Union markets following specific waste collection and never end up in rubbish bins

Contractual warranty

Warranty	18 months
----------	-----------

Dimensions

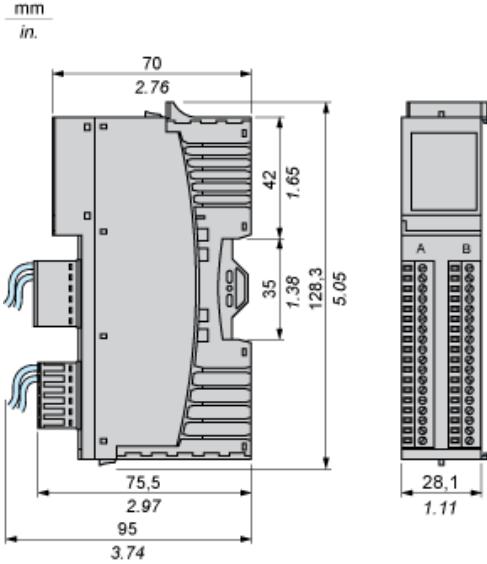

Wiring Diagram

Example

16 two-wire actuators

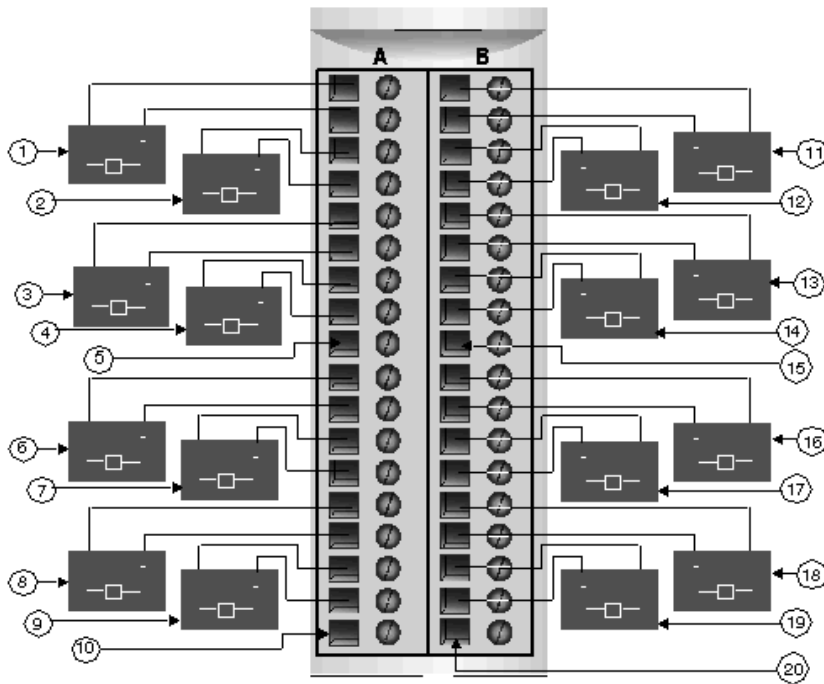

#	Group 1	#	Group 2
1	Channel 1, Connector A, Actuator	11	Channel 1, Connector B, Actuator
2	Channel 2, Connector A, Actuator	12	Channel 2, Connector B, Actuator
3	Channel 3, Connector A, Actuator	13	Channel 3, Connector B, Actuator
4	Channel 4, Connector A, Actuator	14	Channel 4, Connector B, Actuator
5	Pin 9, Connector A (not used)	15	Pin 9, Connector B (not used)
6	Channel 5, Connector A, Actuator	16	Channel 5, Connector B, Actuator
7	Channel 6, Connector A, Actuator	17	Channel 6, Connector B, Actuator
8	Channel 7, Connector A, Actuator	18	Channel 7, Connector B, Actuator
9	Channel 8, Connector A, Actuator	19	Channel 8, Connector B, Actuator
10	Pin 18, Connector A (not used)	20	Pin 18, Connector B (not used)