

Main

Range of product	Modicon X80
Product or component type	Mixed analog I/O module
Electrical connection	20 ways 1 connector
Isolation between channels	Non isolated
Input level	High level
Analogue input number	4
Analogue input type	Current 0...20 mA Current 4...20 mA Voltage +/- 10 V Voltage 0...10 V Voltage 0...5 V Voltage 1...5 V

Complementary

Analogue input resolution	12 bits 0...20 mA 12 bits 0...5 V 12 bits 1...5 V 12 bits 4...20 mA 13 bits 0...10 V 14 bits +/- 10 V
Permitted overload on inputs	+/- 30 mA 0...20 mA +/- 30 mA 4...20 mA +/- 30 V +/- 10 V +/- 30 V 0...10 V +/- 30 V 0...5 V +/- 30 V 1...5 V
Internal conversion resistor	250 Ohm
Precision of internal conversion resistor	0.1 % - 15 ppm/°C
Type of filter	First order digital filtering by firmware
Fast read cycle time	1 ms + 1 ms x number of channels used
Nominal read cycle time	5 ms for 4 channels

Measurement error	0.25 % of full scale 0...20 mA 25 °C output 0.25 % of full scale 4...20 mA 25 °C output <= 0.35 % of full scale +/- 10 V 0...60 °C input <= 0.35 % of full scale 0...10 V 0...60 °C input <= 0.35 % of full scale 0...5 V 0...60 °C input <= 0.35 % of full scale 1...5 V 0...60 °C input <= 0.5 % of full scale 0...20 mA 0...60 °C input <= 0.5 % of full scale 4...20 mA 0...60 °C input <= 0.6 % of full scale +/- 10 V 0...60 °C output <= 0.6 % of full scale 0...20 mA 0...60 °C output <= 0.6 % of full scale 4...20 mA 0...60 °C output 0.25 % of full scale +/- 10 V 25 °C output 0.25 % of full scale +/- 10 V 25 °C input 0.25 % of full scale 0...10 V 25 °C input 0.25 % of full scale 0...5 V 25 °C input 0.25 % of full scale 1...5 V 25 °C input 0.35 % of full scale 0...20 mA 25 °C input 0.35 % of full scale 4...20 mA 25 °C
Temperature drift	100 ppm/°C +/- 10 V output 100 ppm/°C 0...20 mA output 100 ppm/°C 4...20 mA output 30 ppm/°C +/- 10 V input 30 ppm/°C 0...10 V input 30 ppm/°C 0...5 V input 30 ppm/°C 1...5 V input 50 ppm/°C 0...20 mA input 50 ppm/°C 4...20 mA input
Recalibration	Factory calibrated on outputs Internal on inputs
Isolation voltage	1400 V DC between channels and ground 1400 V DC between channels and bus 750 V DC between group of I/O channels
Output level	High level
Analogue output number	2
Analogue output type	Current: 0...20 mA Current: 4...20 mA Voltage: +/- 10 V
Analogue output resolution	11 bits, 0...20 mA 11 bits, 4...20 mA 12 bits, +/- 10 V
Conversion time	<= 2 ms
Maximum conversion value	+/- 11.25 V +/- 10 V output +/- 11.25 V +/- 10 V input 0...30 mA 0...20 mA input 0...30 mA 4...20 mA input +/- 11.25 V 0...10 V input +/- 11.25 V 0...5 V input +/- 11.25 V 1...5 V input 0...24 mA 0...20 mA output 0...24 mA 4...20 mA output
Fallback mode	Predefined Configurable
Protective treatment	TC
Operating altitude	0...2000 m 2000...5000 m with derating factor
Status LED	1 LED (green)RUN: 1 LED per channel (green)channel diagnostic: 1 LED (red)ERR: 1 LED (red)I/O:
Net weight	0.155 kg
Power consumption in W	1.3 W 24 V DC typical 2.8 W 24 V DC maximum 0.35 W 3.3 V DC typical 0.48 W 3.3 V DC maximum

Environment

Vibration resistance	3 gn
----------------------	------

Shock resistance	30 gn
Ambient air temperature for storage	-40...85 °C
Ambient air temperature for operation	0...60 °C
Relative humidity	5...95 % at 55 °C without condensation
IP degree of protection	IP20
Directives	2014/35/EU - low voltage directive 2014/30/EU - electromagnetic compatibility 2012/19/EU - WEEE directive
Product certifications	UL Merchant Navy RCM CSA CE EAC
Standards	EN 61131-2 EN 61000-6-4 EN 61000-6-2 EN 61010-2-201

Offer Sustainability

Sustainable offer status	Green Premium product
REACH Regulation	REACH Declaration
EU RoHS Directive	Pro-active compliance (Product out of EU RoHS legal scope) EU RoHS Declaration
Mercury free	Yes
RoHS exemption information	Yes
China RoHS Regulation	China RoHS declaration
Environmental Disclosure	Product Environmental Profile
Circularity Profile	End of Life Information
WEEE	The product must be disposed on European Union markets following specific waste collection and never end up in rubbish bins

Contractual warranty

Warranty	18 months
----------	-----------

Modules Mounted on Racks

Dimensions

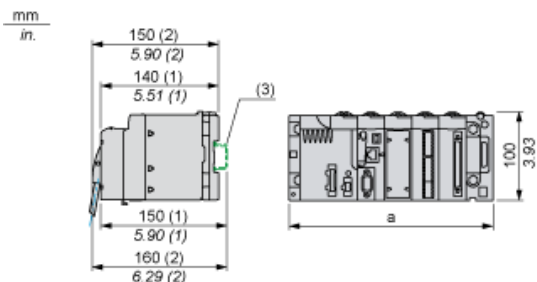

- (1) With removable terminal block (cage, screw or spring).
- (2) With FCN connector.
- (3) On AM1 ED rail: 35 mm wide, 15 mm deep. Only possible with BMXXBP0400/0400H/0600/0600H/0800/0800H rack.

Rack references	a in mm	a in in.
BMXXBP0400 and BMXXBP0400H	242.4	09.54
BMXXBP0600 and BMXXBP0600H	307.6	12.11
BMXXBP0800 and BMXXBP0800H	372.8	14.68
BMXXBP1200 and BMXXBP1200H	503.2	19.81

Wiring Diagram

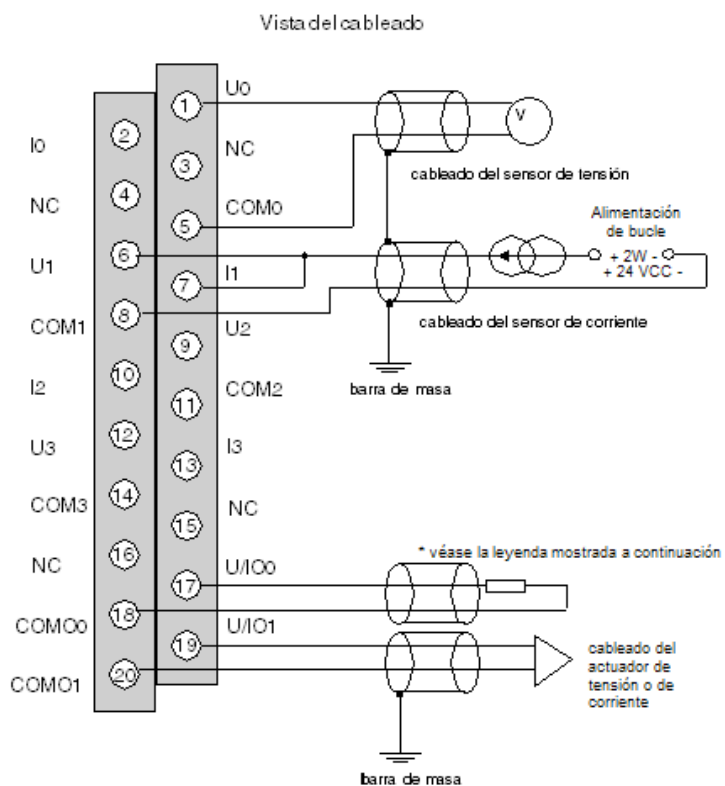

Ux + pole input for channel x

COMx - pole input for channel x

U/IOx + pole output for channel x

COMOx - pole output for channel x

* The current loop is self-powered by the output and does not request any external supply.